



MANTICORE ARMS, INC.

Advanced Fighting Gear

MADE IN



U. S. A.

TRANSFORMER RAIL FOR AR-15 INSTALLATION INSTRUCTIONS

Warning: Always verify your rifle is unloaded prior to installing any parts!

The Transformer Rail for AR-15 is compatible with the following firearms:

All standard AR-15 and M-16 uppers (A1, A2, A3)

The following is included in the kit:

- (1) Transformer Rail
- (1) Grooved Aluminum Barrel Nut
- (1) Barrel Nut Wrench
- (4) 6-32 x 1/8" set screws
- (4) 6-32 x 3/16" set screws
- (1) 5/64" allen wrench
- (1) 3/32" allen wrench

(May also include Transformer Panels of various types along with mounting hardware)



You will need the following tools:

- 1/2" torque wrench
- Lithium grease
- Upper receiver clamp block and vise
- Tools to install gas block, gas tube, and muzzle device

STEP 1:

Place barrel nut on barrel, and then install gas block, and gas tube.

STEP 2:

Place upper in clamp block and vise, and put barrel in front of upper receiver make sure to seat it properly. Grease the threads of the upper with lithium grease, and hand tighten the barrel nut down.

STEP 3:

Install barrel nut wrench on 1/2" torque wrench and set torque wrench to 50 ft lbs. Place barrel nut wrench into slots on front of barrel nut and tighten barrel nut until wrench clicks.

STEP 4:

Slide the Transformer Rail onto the barrel nut. Thread the (4) 6-32 x 1/8" set screws on the upper holes and thread the (4) 6-32 x 3/16" screws into the underside holes. Tighten the screws down until snug and flush with the surface of the rail. The screws have engaged the grooves in the barrel nut and the rail is now installed!

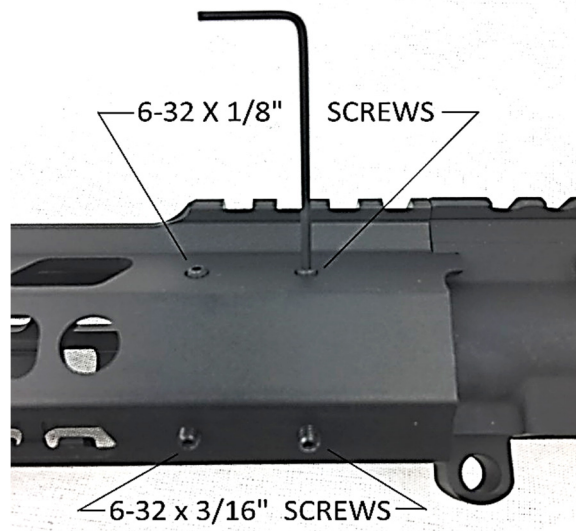

TRANSFORMER PANEL INSTALLATION:

Use the included 3/32" allen wrench to install the polymer grip panels with the round head 8-32 x 1/4" screws (included with polymer grip panels) or the aluminum M-LOK or Keymod panels with the flat head 8-32x1/4" screws (included with aluminum grip panels). Torque down until the end of the wrench stars to bend. (25-30 INCH lbs)

Visit www.youtube.com/manticorearms to view videos on the installation and use of this product!

Manticore Arms, Inc.

747 Herra Street
Unit A
Elburn, Illinois 60119

Phone: 866-331-9472
Email: Info@ManticoreArms.com
Revised: 01/15/2020

www.ManticoreArms.com